

# **The November Knot**

**and Other Dances  
for Teaching**

New country dances  
in the Scottish tradition  
by Anselm Lingnau

# Contents

Dancing in Autumn (Jig) . . . . .	2
The November Knot (Strathspey) . . . . .	3
Wheels Up (Reel) . . . . .	4
On Tour(née) (Strathspey) . . . . .	5
The Main River Promenade (Jig) . . . . .	6
Sunday Rain (Strathspey) . . . . .	7
A Trip to the Highlands (Reel) . . . . .	8
The First Snow of December (Jig) . . . . .	9
Birgit Röhrich’s Strathspey (Strathspey) . . . . .	10
The São Jorge Whale-Watchers (Reel) . . . . .	11
A Trip to Tallinn (Strathspey) . . . . .	12
Autumn Colours (Jig) . . . . .	13
Tuesday Corners (Reel) . . . . .	14
Music Suggestions . . . . .	15
Teaching Overview . . . . .	17

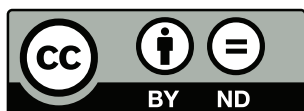

This collection © 2024 by Anselm Lingnau  
(Version 1.1 of 20th February 2024).

“The November Knot” is published under a “Creative Commons Attribution-NoDerivs 4.0 International License”.

This means:

- You are free to make and give away unmodified copies of this book
- If you remix, transform, or build upon the material in this book, you may not distribute the modified material.

See <https://creativecommons.org/licenses/by-nd/4.0/> for details.

# Introduction

The first six dances in this book were devised for a teachers' workshop in November 2009 and then duly forgotten about completely. In 2023 I re-discovered the file in a remote corner of my computer's disk and decided to give the dances an official existence.

The other dances came about to support specific lessons in my regular class at the Frankfurt SCD Club e.V. as well as workshops in Germany and abroad.

Each of the dances showcases a particular formation and could be used when that formation is taught in class.

- *Dancing in Autumn*: Rights and lefts for three couples
- *The November Knot*: Knot
- *Wheels Up*: Spoke
- *On Tour(née)*: Tournée
- *The Main River Promenade*: Promenade (with a cast)
- *Sunday Rain*: Strathspey pousette
- *A Trip to the Highlands*: Figure of eight across the dance
- *The First Snow of December*: Setting twice
- *Birgit Röhricht's Strathspey*: Promenade
- *The São Jorge Whale-Watchers*: Ladies' Chain
- *A Trip to Tallinn*: 2-couple allemande
- *Autumn Colours*: Figures of eight/reels of three, 2-couple circulating allemande
- *Tuesday Corners*: Dance to corners and set



— Anselm Lingnau  
Mainz, Germany  
February 2024

This book was typeset by the author using the  $\text{\LaTeX}$  typesetting suite on a PC running the Linux operating system. The text is set in Optima.

# Dancing in Autumn

A 32-bar jig for 3 couples in a 4-couple longwise set

BARS	DESCRIPTION
1–4	1st couple cast off one place (2nd couple move up on bars 3–4).
5–16	2nd, 1st, and 3rd couples dance rights and lefts for three couples.
17–24	1st couple dance reels of three with their corners, giving right shoulder to second corner to begin.
25–28	1st couple dance half figures of eight around partner's first corner to finish in second place on own sides.
29–32	2nd, 1st, and 3rd couples, giving right hands, turn once round. Repeat, having passed a couple.

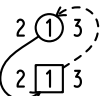
DANCING IN AUTUMN		Lingnau: November Knot	J32
 (2)	     (12 bars)		       213 T R

# The November Knot

A 32-bar strathspey for 3 couples in a 4-couple longwise set

**BARS**

**DESCRIPTION**

- 1–8 1st couple cast off behind own lines and back.
- 9–16 1st and 3rd couples dance a double figure of eight, 1st couple crossing down and 3rd couple casting up to begin.
- 17–24 1st and 2nd couples dance the Knot.
- 25–32 2nd, 1st, and 3rd couples dance six hands round and back.  
Repeat, having passed a couple.

THE NOVEMBER KNOT		Lingnau: November Knot	S32
<p>A diagram of a 4-couple line. The top row consists of four boxes labeled 1, 2, 3, and 4. The bottom row consists of four circles labeled 1, 2, 3, and 4. A dashed arrow above the boxes points from 1 to 2, 2 to 3, and 3 to 4. A solid arrow below the circles points from 4 to 3, 3 to 2, and 2 to 1.</p>	<p>A diagram showing a double figure of eight between couples 1 and 3. The top row has boxes 1 and 3. The bottom row has circles 1 and 3. A dashed arrow above the boxes points from 1 to 3. A solid arrow below the circles points from 3 to 1. A curved arrow on the left indicates a counter-clockwise rotation.</p> <p>Dbl Fig of 8</p>	<sup>12</sup> KNOT	<p>6</p>

# Wheels Up

A 32-bar reel for 3 couples in a 4-couple longwise set

BARS	DESCRIPTION
1–8	1st couple set, cross over giving right hands, cast off (2nd couple move up) and, giving left hands, turn three-quarters round to join hands with 1st corners.
9–16	1st couple and their corners dance the Spoke.
17–24	1st man and 3rd couple, 1st woman and 2nd couple, dance reels of three across the dance, giving left shoulders to first corners to begin. 1st couple finish in second place on own sides.
25–28	1st and 3rd couples dance right hands across.
29–32	2nd and 1st couples dance left hands across.

Repeat, having passed a couple.

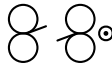
WHEELS UP	Lingnau: November Knot		R32
$S X_R \uparrow_{(2)} T_{L 3/4}$	SPOKE		$\begin{matrix} 13 &   & 21 \\ RA &   & LA \\ &   & \end{matrix}$

# On Tour(née)

A 32-bar strathspey for 2 couples in a 4-couple longwise set

BARS	DESCRIPTION
1–4	1st and 2nd couples set and dance four hands round to the left half-way.
5–8	2nd and 1st couples set and link.
9–12	1st and 2nd couples set and dance four hands round to the left half-way.
13–16	2nd and 1st couple set and reverse-link (left-hand person casts, right-hand person goes through the middle).
17–24	1st couple, crossing down to begin, dance a figure of eight around 2nd couple.
25–32	1st and 2nd couple dance the Tournée.

Repeat, having passed a couple.

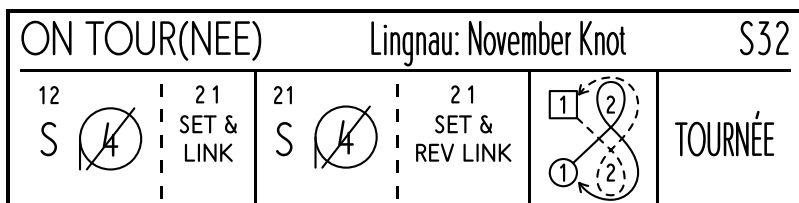

# The Main River Promenade

A 32-bar jig for 3 couples in a 4-couple longwise set

BARS	DESCRIPTION
1–8	1st couple, dancing in and down to begin, dance a full figure of eight around 2nd and 3rd couples. They finish in the middle of the set in first place in promenade hold. On bar 8, 2nd and 3rd couples step in behind them to face up in promenade hold.
9–16	1st, 2nd, and 3rd couples promenade. On bars 15–16, 1st couple cast off one place while 2nd couple dance up to the top.
17–24	1st couple dance down and cast up round 3rd couple, meet, dance up and cast off around 2nd couple.
25–28	1st man and 3rd couple, likewise 1st woman and 2nd couple, dance right hands across.
29–32	1st man and 2nd couple, likewise 1st woman and 3rd couple, dance left hands across.

Repeat, having passed a couple.

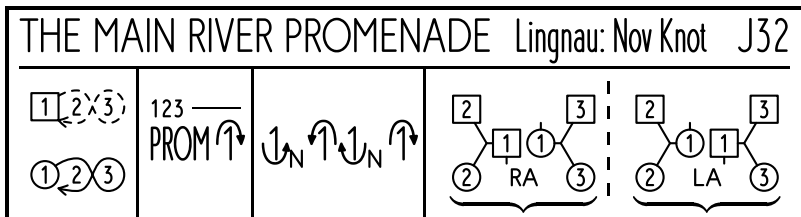



# Sunday Rain

A 32-bar strathspey for 3 couples in a 4-couple longwise set

- | BARS  | DESCRIPTION   |
|-------|---|
| 1–8   | 1st and 2nd couples set, turn once round giving both hands, and continue into four hands round to the left. They finish in the centre of the set facing down. |
| 9–12  | 2nd couple, followed by 1st couple, dance down the middle (using small steps)   |
| 13–16 | 1st couple, followed by 2nd couple, dance up the middle. On bars 15–16, 1st couple cast off one place while 2nd couple dance up to the top and face out.      |
| 17–24 | 2nd, 1st, and 3rd couples dance reels of three on the sides, 1st couple dancing in and down to begin. All take nearer hands where possible.                   |
| 25–32 | 2nd and 1st couples dance a pousette.<br>Repeat, having passed a couple.  |

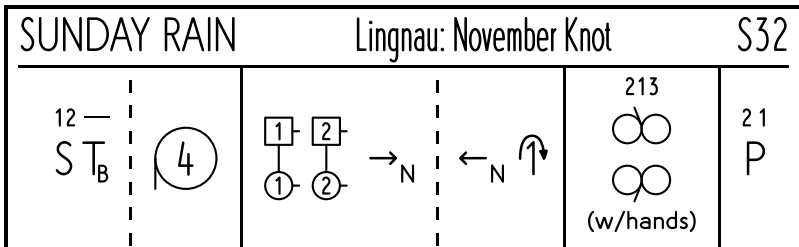

# A Trip to the Highlands

A 32-bar reel for 2 couples in a 4-couple longwise set

BARS	DESCRIPTION
1–8	1st couple dance a figure of eight around 2nd couple.
9–16	1st and 2nd couples turn partners giving rights hand then turn partners giving left hands.
17–20	1st couple followed by 2nd couple lead down the middle.
21–24	2nd couple followed by 1st couple lead up the middle, 2nd couple finishing in first place, 1st couple in second place.
25–32	2nd and 1st couples dance rights and lefts.

Repeat, having passed a couple.

In February 2015, I taught a weekend workshop in St. Petersburg, Russia. I had a one-hour session to teach beginners some simple formations and dances and originally wanted to use *The Highland Fair* from the RSCDS *Book of Graded Scottish Country Dances*. However, I didn't want both of the dances I used in that class to be jigs, so I tweaked that dance a little and changed it to a reel.

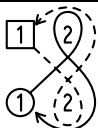
A TRIP TO THE HIGHLANDS		Lingnau: Nov Knot	R32
	$\begin{array}{c} 12 \text{ ---} \\ \text{T}_R \text{ T}_L \end{array}$	$\begin{array}{c} 12 \quad   \quad 21 \\ \rightarrow \quad   \quad \leftarrow \end{array}$	RL



# The First Snow of December

A 32-bar jig for 2 couples in a 4-couple longwise set

BARS	DESCRIPTION
1–4	1st and 2nd couples set twice.
5–8	1st and 2nd couples dance right hands across, finishing in the middle with nearer hands joined with partners, 1st couple facing down, 2nd couple facing up.
9–12	1st and 2nd couples set twice.
13–16	1st and 2nd couples dance left hands across, finishing in original places.
17–24	1st couple lead down for three steps, up for three steps, and cast off to second place. 2nd couple move up on bars 23–24.
25–32	2nd and 1st couples dance four hands round and back.

Repeat, having passed a couple.

A very simple practice dance for pas de basque.

THE FIRST SNOW OF DECEMBER		Lingnau: November Knot	J32
$12$ ——— $S_2$ RA		$12$ ——— $S_2$ LA	$\Leftrightarrow$ 
			

# Birgit Röhrich's Strathspey

A 32-bar strathspey for 3 couples in a 4-couple longwise set

BARS	DESCRIPTION
1–4	1st couple set advancing and turn once round giving both hands, finishing in the middle of the set facing down.
5–8	1st couple lead down, crossing below 3rd couple, and cast up to second place (2nd couple move up).
9–12	2nd, 1st, and 3rd couples advance and retire.
13–16	2nd, 1st, and 3rd couples turn once round giving both hands.
17–20	2nd and 1st couples dance four hands round to the left, finishing in the sidelines.
21–24	2nd couple cast off and lead up to the top <b>while</b> 1st couple cross up (no hands) and cast off. On bar 24, 3rd couple dance in. All finish in the middle facing up in promenade hold.
25–32	2nd, 1st, and 3rd couples dance a promenade.

Repeat, having passed a couple.

This is the oldest dance in this book. I wrote it in 1997 after taking the RSCDS Preliminary Test when I was looking for a dance to teach the promenade (other than *The Birks of Invermay*).

Birgit lives in Westphalia and took part in our Prelim class and exam that year.

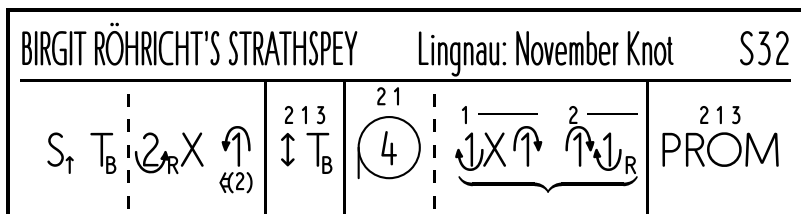

# The São Jorge Whale-Watchers



A 32-bar reel for 2 couples in a 4-couple longwise set

BARS	DESCRIPTION
1–8	1st couple set, cast off (2nd couple move up), and dance a half figure of eight around the 2nd couple.
9–16	2nd and 1st couples dance a ladies' chain.
17–24	1st couple set, dance up, cast off round 2nd couple, and giving right hands cross over to own sides in second place.
25–32	2nd and 1st couple dance rights and lefts.

Repeat, having passed a couple.

This dance is a reminder of an utterly dismal afternoon out on the Atlantic ocean, bouncing about in a tiny boat, in the gusty wind and pouring rain near the Azorean island of São Jorge (soft J). I don't recall ever being as completely soaked through as on that day. We did get to see some Risso's dolphins (Pelorus Jack's European relations), which we were told are very rarely encountered in the area, so that made up for all the hardships, to a degree.

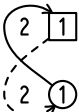
Use hornpipe music.

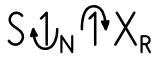
THE SAO JORGE WHALE-WATCHERS		Lingnau: November Knot	R32	
				RL

# A Trip to Tallinn

A 32-bar strathspey for 3 couples in a 3-couple set

BARS	DESCRIPTION
1–8	1st couple, giving both hands, turn once round, dance down the middle for two steps, turn again once round giving both hands, and dance up the middle to the top again. On bar 8, 2nd couple dance in.
9–16	1st and 2nd couples dance an allemande.
17–20	1st and 3rd men turn once round giving right hands <b>while</b> 1st and 3rd women turn once round giving left hands.
21–24	1st and 3rd couples set and link.
25–32	2nd, 3rd, and 1st couples dance six hands round and back.

Repeat from new positions.

I wrote this dance for my teaching visit to Estonia in June 2014. Marie and I were very well looked after by Eike Urke of Tallinn and her family, who not only put us up at their place but also showed us around their home city and various other places in this tiny but beautiful and hospitable country. Great memories.

A TRIP TO TALLINN (3c)		Lingnau: November Knot		S32
$T_B \rightarrow_N T_B \leftarrow_N$	21 A	13 $T \leftarrow_N$	13 SET & LINK	6

# Autumn Colours

A 32-bar jig for 3 couples in a 4-couple longwise set

BARS	DESCRIPTION
1–4	1st and 2nd couples dance right hands across. 1st woman finishes facing out.
5–8	1st woman followed by her partner casts off round 2nd woman and dances across to 2nd man's place, facing out. 1st man finishes in 2nd woman's place. 2nd couple move up on bars 7–8.
9–16	1st couple dance figures of eight on opposite sides, giving right shoulders to 2nd couple to begin. 1st couple finish in 2nd place, 1st woman facing out.
17–20	1st and 3rd couples dance left hands across.
21–24	1st couple cross down between 3rd couple and cast up.
25–32	2nd, 1st, and 3rd couples dance six hands round and back.

Repeat, having passed a couple.

Another teaching dance from the Frankfurt SCD Club, devised in September 2023. Feel free to substitute right-shoulder reels of three on opposite sides for the figures of eight in bar 9–16 if you would like to use this dance for reel-of-three practice.

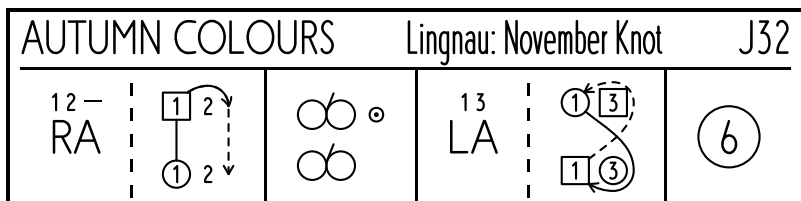

# Tuesday Corners

A 32-bar reel for 3 couples in a 4-couple longwise set

- | BARS  | DESCRIPTION   |
|-------|---|
| 1–2   | 1st couple turn halfway giving right hands, moving down to the middle of the set in second place (2nd couple move up).                                |
| 3–4   | 1st couple set, pulling right shoulders back to turn about on bar 4 to finish facing first corners.   |
| 5–16  | 2nd, 1st and 3rd couples dance to corners and set, At the end, 1st couple pass left shoulders to finishing facing third corner positions.             |
| 17–20 | 1st couple and first corners dance half a diagonal reel of four. At the end, 1st couple pass left shoulders to finish facing fourth corner positions. |
| 21–24 | 1st couple and second corners dance half a diagonal reel of four. 1st couple finish in second place on own sides.                                     |
| 25–28 | 1st woman with 2nd couple, 1st man with 3rd couple dance right hands across.  |
| 29–32 | 1st man with 2nd couple, 1st woman with 3rd couple dance left hands across.   |

Repeat, having passed a couple.

A dance to practice Dance to Corners and Set. I tried this dance in class with a different ending which frankly sucked – so I hope that this one will work better! Tuesday is the Frankfurt SCD Club’s dance night.

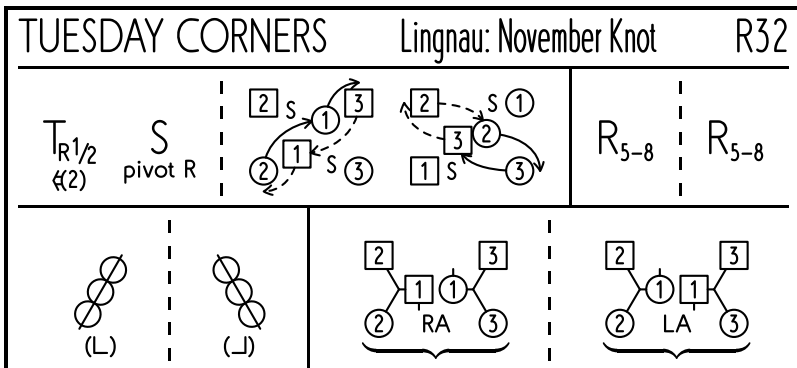



# Music Suggestions

Here are some suggestions for tunes and recorded music for these dances.

## **Autumn Colours** (8J32)

*Tune:* Mr Morison of Bognie (Wm. Marshall)

- ▶ Holden My Own (*A Dancer's Best Friend*, by Terpsichore)
- ▶ Kiss Under the Stairs (*H.I.S.C.D.*, by Bobby Brown et al.)
- ▶ Mr Morison (*Gang on the Same Gate*, by Green Ginger)
- ▶ Mr Morrison (*A Dancing Master Remembered*, by Jennifer Wilson)

## **Birgit Röhricht's Strathspey** (8S32)

*Tune:* Miss Birgit Röhricht of Bielefeld (A. Lingnau)

- ▶ Dr Neil S MacLeod (*Carriages at Midnight*, by Chris Duncan & Catherine Strutt)

## **Dancing in Autumn** (8J32)

*Tune:* Miss J. Rose's Reel (Robt. Mackintosh)

- ▶ Come Under My Plaidie (*RSCDS Book 40*, by The Craigowl Scottish Dance Band)

## **The First Snow of December** (8J32)

*Tune:* Miss McPherson Grant's Jig (of Ballindalloch) (Wm. Marshall)

- ▶ The Nurseryman (by any number of artists)

## **The Main River Promenade** (8J32)

*Tune:* Parnell's Dragoons (Trad.)

- ▶ Parnell's Dragoons (*Crossing Borders*, by Chris, Julie & Nick Dewhurst)

## **The November Knot** (8S32)

*Tune:* Lady Louisa Gordon's Strathspey (Robt. Mackintosh)

- ▶ Peggy's Love (*Old Favourites and Odd Couples*, by Catherine Fraser & Duncan Smith)
- ▶ Peggy's Love (*Live From C Sharp*, by Pinewoods 2010 Musicians)
- ▶ Peggy's Love (*Memory Lane*, by Various Artists)

## **On Tour(née)** (8S32)

*Tune:* Earl Grey (James Hill)

- ▶ Linnea's Strathspey (*Book 47*, by Gordon Shand and his Scottish Dance Band)
- ▶ Linnea's Strathspey (*Excited States*, by StringFire!)

### **The São Jorge Whale-Watchers** (8R32)

*Tune:* Kirk's Hornpipe (Trad.)

- ▶ Set of Hornpipes (*Kardinia Capers*, by David South and his Scottish Dance Band)

### **Sunday Rain** (8S32)

*Tune:* In the Garb of Old Gaul (Trad.)

- ▶ In Garb of Old Gaul (*Dances to Song Tunes*, by Iain Cathcart and his Band)

### **A Trip to the Highlands** (8R32)

*Tune:* Saint Columba's Sword (Trad.)

- ▶ Lobster in the Pot (*Music for A Whale of a Time*, by Peter Elmes' SCD Band)
- ▶ Mrs Litten's Reel (*Berkhamsted Golden Jubilee*, by Barbara Manning & Ken Martlew)

### **A Trip to Tallinn** (3S32)

*Tune:* The Tallinn Town Hall Home-Made Medieval Elk Soup Incident (A. Lingnau)

- ▶ A Couple of Keepers (*Excited States*, by StringFire!)
- ▶ Hope Little's Strathspey (*Haste Ye Back*, by Muriel Johnstone's Scottish Dance Band)

### **Tuesday Corners** (8R32)

*Tune:* The Reel of Tullochgorum

- ▶ Set of Reels (*After the Chord*, by The Craigellachie Band)

### **Wheels Up** (8R32)

*Tune:* At the Fair

- ▶ The Music Makars (*Take Your Partners For . . . Vol. 5*, by Luke Brady's Scottish Dance Band)
- ▶ Music Makars (*Scottish Dance Music*, by The Music Makars)
- ▶ The Music Makars (*Dance for Joy!*, by Reel of Seven)
- ▶ The Music Makars (*Cairngorms*, by Keith Smith & Muriel Johnstone)
- ▶ The Music Makars (*Book 33*, by Kenny Thomson and the Wardlaw SCD Band)

# Teaching Overview

The following diagram shows the “dependencies” among the different dances. We assume that dancers are familiar with the “basics” like turns, leading/dancing up/down, and simple formations such as Hands Round, Hands Across, and Rights and Lefts. Some of the dances also contain more advanced formations not introduced in this book. Obviously the dances in this book should be used together with dances from other sources to provide a comprehensive dancing experience.

